



BYC Series Butterfly Valves

2" TO 8" PVC

KEY FEATURES

- Wafer Body Design
- PVC Body with PVC Disc
- 316 Grade Stainless Steel Stem
- ISO 5211 Mounting Pad
- Standard Lockout

OPTIONS

- Gear Operators
- Pneumatic or Electric Actuators

MATERIALS

- PVC Cell Class 12454 per ASTM D1784

TECHNICAL INFORMATION

ACTUATED VALVE



SELECTION CHART

SIZE	BODY MATERIAL	DISC MATERIAL	LINERS	PRESSURE RATING
2" – 6" (DN50 – DN150)	PVC	PVC	EPDM	150 PSI @ 70°F Non-Shock
8" (DN200)				100 PSI @ 70°F Non-Shock

BYC Series Butterfly Valves

2" TO 8" PVC

TECHNICAL INFORMATION, CONTINUED

PARTS LIST

1. Operator (Lever or Gear box)
2. Disc
3. Body
4. Liner

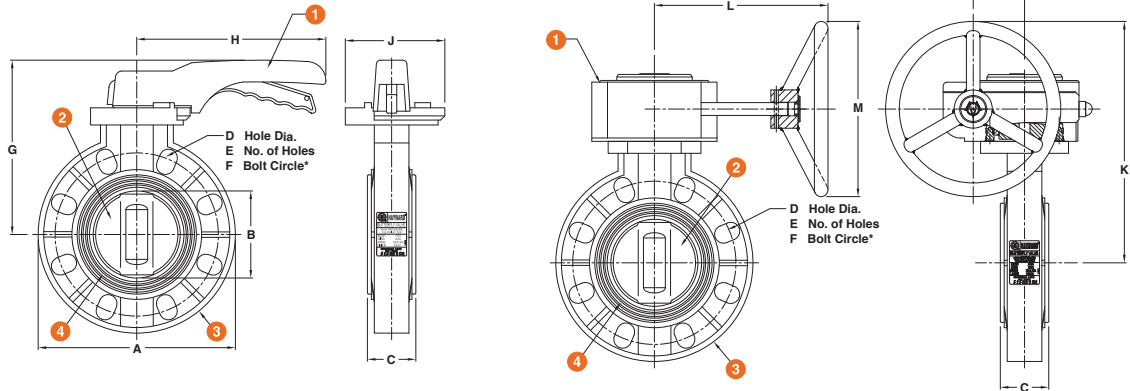

* Fits PN10 Flanges

DIMENSIONS – INCHES / MILLIMETERS

SIZE in / DN	A	B	C	D	E	F	G	H	J	K	L	M	N
2 / 50	6.30 / 160	2.13 / 54	1.75 / 44	.75 / 19	4 / 102	4.75 / 121	6.37 / 162	8.66 / 220	4.26 / 108	9.52 / 242	9.69 / 246	8.00 / 203	2.36 / 60
2-1/2 / 63	7.08 / 180	2.64 / 67	1.89 / 48	.75 / 19	4 / 102	5.50 / 140	6.73 / 171	8.66 / 220	4.26 / 108	9.88 / 251	9.69 / 246	8.00 / 203	2.36 / 60
3 / 80	7.70 / 196	3.27 / 83	2.09 / 53	.75 / 19	4 / 102	6.00 / 152	7.44 / 189	9.80 / 249	8.43 / 214	10.59 / 269	9.69 / 246	8.00 / 203	2.36 / 60
4 / 100	9.06 / 230	3.98 / 101	2.24 / 57	.75 / 19	8 / 203	7.50 / 191	7.95 / 202	9.80 / 249	4.26 / 108	11.10 / 282	9.69 / 246	8.00 / 203	2.36 / 60
5 / 125	10.00 / 254	5.00 / 127	2.68 / 68	.88 / 22	8 / 203	8.50 / 216	9.96 / 253	12.60 / 320	5.84 / 148	12.34 / 313	9.69 / 246	8.00 / 203	2.36 / 60
6 / 150	11.19 / 284	5.98 / 152	2.87 / 73	.88 / 22	8 / 203	9.50 / 241	10.48 / 266	12.60 / 320	5.84 / 148	12.86 / 326	9.69 / 246	8.00 / 203	2.36 / 60
8 / 200	13.54 / 344	7.88 / 200	3.62 / 92	.88 / 22	8 / 203	11.75 / 298	12.17 / 309	12.60 / 320	5.84 / 148	14.55 / 370	9.69 / 246	8.00 / 203	2.36 / 60

Dimensions are subject to change without notice – consult factory for installation information

Cv VALUES

DISC ANGLE	15°	30°	45°	60°	75°	FULL OPEN
SIZE in / DN	Cv VALUES					
2 / 50	1	6	24	32	84	120
2-1/2 / 63	3	13	50	108	175	250
3 / 80	4	15	60	129	210	300
4 / 100	7	24	94	202	329	470
5 / 125	13	42	166	357	581	830
6 / 150	18	55	220	473	770	1,100
8 / 200	90	125	500	1,075	1,750	2,500

PRESSURE LOSS CALCULATION FORMULA

$$\Delta P = \left[\frac{Q}{C_v} \right]^2$$

ΔP = Pressure Drop
 Q = Flow in GPM
 C_v = Flow Coefficient

OPERATING TEMPERATURE / PRESSURE

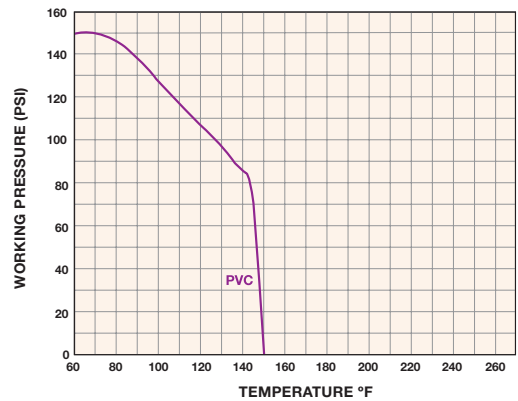

Hayward is a registered trademark of Hayward Industries, Inc. © 2011 Hayward Industries, Inc.

Contact Hayward Flow Control with questions: 1-888-429-4635 • Fax: 1-888-778-8410 • One Hayward Industrial Drive • Clemmons, NC 27012 • USA
 Visit us at: www.haywardflowcontrol.com • E-mail: hflow@haywardnet.com