



HAYWARD® INDUSTRIAL PRODUCTS INC.

INSTALLATION OPERATION & MAINTENANCE MANUAL Rack and Pinion Pneumatic Actuators

PLEASE READ THE FOLLOWING INFORMATION PRIOR TO INSTALLING AND USING HAYWARD VALVES, STRAINERS, FILTERS, AND OTHER ASSOCIATED PRODUCTS. FAILURE TO FOLLOW THESE INSTRUCTIONS MAY RESULT IN SERIOUS INJURY.

1. Hayward guarantees its products against defective material and workmanship only. Hayward assumes no responsibility for damage or injuries resulting from improper installation, misapplication, or abuse of any product.
2. Hayward assumes no responsibility for damage or injury resulting from chemical incompatibility between its products and the process fluids to which they are subjected. Compatibility charts provided in Hayward literature are based on ambient temperatures of 70 °F and are for reference only. Customer should always test to determine application suitability.
3. Consult Hayward literature to determine operating pressure and temperature limitations before installing any Hayward product. Note that the maximum recommended fluid velocity through any Hayward product is eight feet per second. Higher flow rates can result in possible damage due to the water hammer effect. Also note that maximum operating pressure is dependent upon material selection as well as operating temperature.
4. Hayward products other than pneumatic actuators are designed primarily for use with non-compressible liquids. Hayward products other than pneumatic actuators should NEVER be used or tested with compressible fluids such as compressed air or nitrogen.
5. Systems should always be depressurized and drained prior to installing or maintaining Hayward products.
6. Temperature effect on piping systems should always be considered when the systems are initially designed. Piping systems must be designed and supported to prevent excess mechanical loading on Hayward equipment due to system misalignment, weight, shock, vibration, and the effects of thermal expansion and contraction.
7. Because PVC and CPVC plastic products become brittle below 40 °F, Hayward recommends caution in their installation and use below this temperature.
8. Published operating torque requirements are based upon testing of new valves using clean water at 70 °F. Valve torque is affected by many factors including fluid chemistry, viscosity, flow rate, and temperature. These should be considered when sizing electric or pneumatic actuators.
9. Due to differential thermal expansion rates between metal and plastic, transmittal of pipe vibration, and pipe loading forces **DIRECT INSTALLATION OF METAL PIPE INTO PLASTIC CONNECTIONS IS NOT RECOMMENDED**. Wherever installation of plastic valves into metal piping systems is necessary, it is recommended that at least 10 pipe diameter in length of plastic pipe be installed upstream and downstream of the plastic valve to compensate for the factors mentioned above.

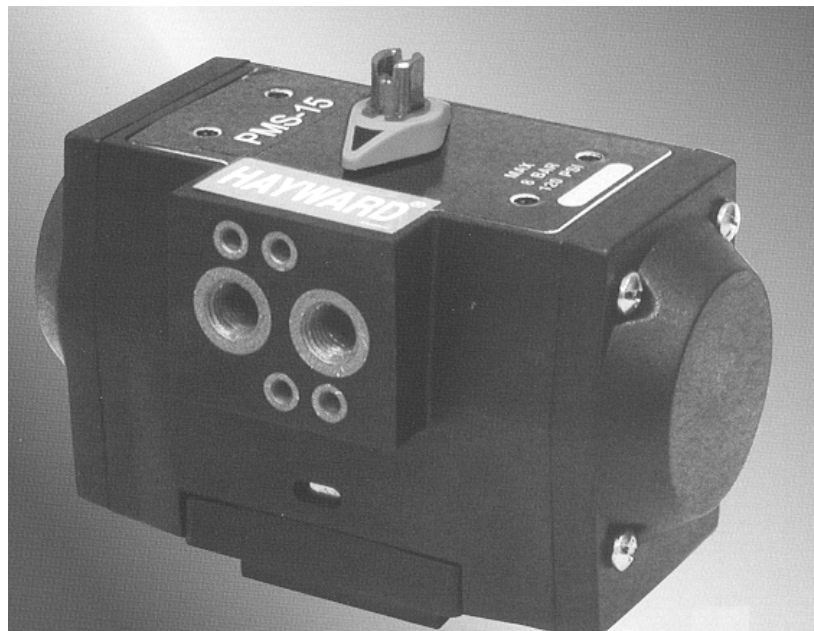

HAYWARD INDUSTRIAL PRODUCTS INC.

One Hayward Industrial Drive
Clemmons, NC 27012
Phone: 336-712-9900 Fax: 336-712-9518
www.haywardflowcontrol.com

PMSIOM

Rev. B
Aug 10, 2004
ECR 681T
Page 1 of 4

Operation:

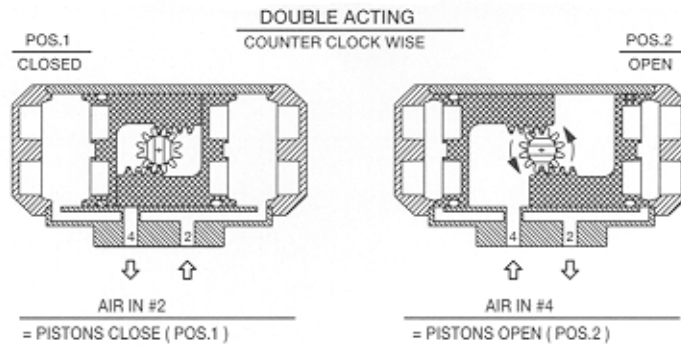

Hayward Industrial Products Inc. offers two different pneumatic rack and pinion actuators, double acting and spring return. These actuators are designed to operate with dry and lubricated compressed air. They will function equally well with non-corrosive and inert gas or light hydraulic oil.

Double Acting

Rotation occurs when compressed air is supplied to the actuator through Port 4, connected to the interior cavity between the pistons, or through Port 2, connected to the end cap area.

1. As shown above pressure to Port 2 fills the outboard cavities, pushing both pistons inward and exhausting air through Port 4.
2. As shown above pressure to Port 4 fills the inboard cavities, pushing both pistons outward and exhausting air through Port 2. As the pistons extend they rotate the shaft counter clockwise (when viewed from the top of the actuator).

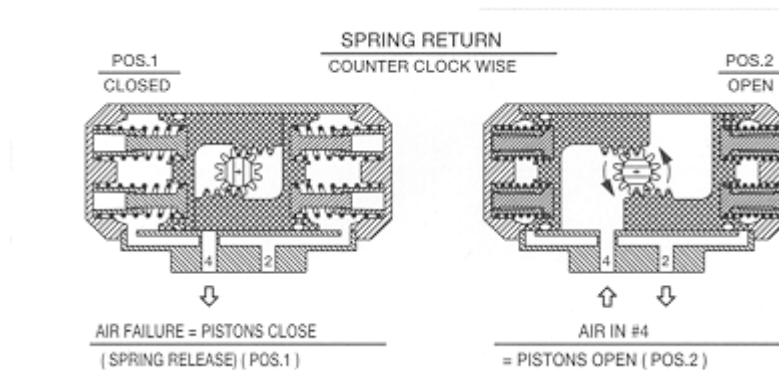

Spring Return

Rotation occurs when compressed air is supplied to the actuator through Port 4, connected to the interior cavity between the pistons, the springs provide the return force.

As shown above pressure to Port 4 fills the inboard cavities, pushing both pistons outward and exhausting air through Port 2. As the pistons extend they rotate the shaft counter clockwise (when viewed from the top of the actuator and compress the springs).

HAYWARD INDUSTRIAL PRODUCTS INC.

One Hayward Industrial Drive
Clemmons, NC 27012
Phone: 888-429-4635 Fax: 888-778-8410
www.haywardflowcontrol.com

PMSIOM

Rev. B
Aug 10, 2004
ECR 681T
Page 2 of 4

1. Operating Media: Dry or lubricated air, non-corrosive and inert gas or light hydraulic oil.
2. Air supply: 80 PSIG (5.6 Bar) recommended.
3. Operating Temperature: -4 °F to +176 °F (-20 °C to 80 °C)
4. Lubrication: Factory lubricated for life under normal working conditions with EXXON CAZAR K2 or equal.

DO NOT DISASSEMBLE THE ACTUATOR WHILE AIR PRESSURE IS APPLIED TO ACTUATOR.

Installation procedure.

1. Check the coupling fits both the actuator and the valve.
2. Make sure both the valve and the actuator are both in the **closed** position.
3. Place the coupling on the valve stem and mount the bracket on the actuator. Align valve and actuator. Tighten all assembly fasteners.
4. Actuate the unit several times to ensure that it works properly.

Maintenance procedure:

Maintenance instructions provide the end user with the necessary information for standard examination of O-rings and soft wear parts.

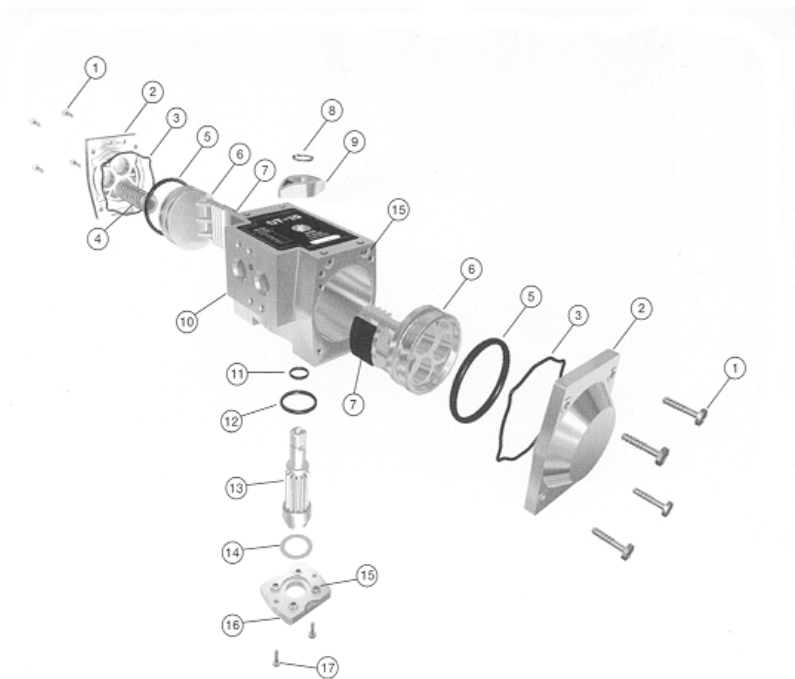

- | | | |
|---------------------|-------------------------|------------------|
| 1. End cap screw | 7. Piston skate | 13. Pinion |
| 2. End cap | 8. Snap ring | 14. Washer |
| 3. End cap o-ring | 9. Indicator | 15. Nut |
| 4. Spring cartridge | 10. Body | 16. Flange |
| 5. Piston o-ring | 11. Upper pinion o-ring | 17. Flange screw |
| 6. Piston | 12. Lower pinion o-ring | |

HAYWARD INDUSTRIAL PRODUCTS INC.

One Hayward Industrial Drive
 Clemmons, NC 27012
 Phone: 336-712-9900 Fax: 336-712-9518
www.haywardflowcontrol.com

PMSIOM

Rev. B
 Aug 10, 2004
 ECR 681T

CAUTION – PLEASE READ AND UNDERSTAND:

- 1. BEFORE ANY MAINTENANCE IS PERFORMED, IT IS ESSENTIAL THAT THE ACTUATOR IS NOT UNDER PRESSURE AND IT IS FREE OF ALL ACCESSORIES.**
- 2. FOR YOUR SAFETY, IT IS NECESSARY, BEFORE DISASSEMBLING A SPRING RETURN ACTUATOR, THAT THE UNIT IS IN THE FAILSAFE POSITION (SPRINGS EXTENDED).**

O-Rings and Piston Stake

1. Disconnect all electrical and air supplies from the actuator.
2. Remove the actuator from the mounting bracket and place in a clean environment.
3. After removing the end cap screws (ref 1), remove the end caps (ref 2)
4. Remove O-rings (ref 3) from the end caps and inspect for wear and damage.
5. Using a wrench on the top of the pinion (ref 13), turn the pinion counter-clockwise until the pistons (ref 6) protrude out and can be removed.
6. Remove the O-rings (ref 5), Piston stake (ref 7) from the left and right pistons.
7. Remove Snap ring (ref 8) from top of actuator.
8. Remove position indicator.
9. Remove the screws (ref 17) from the bottom side of the flange (ref 16). Turn the unit over. Tap on the top of the pinion utilizing a wood surface, to remove.
10. Remove the washer (ref 14).
11. Remove O-rings (ref 11, and 12)
12. Inspect and replace worn parts.

Reassembly:

1. Install O-rings and Piston stake on pistons.
2. Insert both piston racks on the left of where the pinion will go. Apply hand pressure until the piston racks just touch.
3. Install the o-rings on the pinion.
4. Carefully align the flats on the top of the pinion 90° to the pistons. Install the pinion into the actuator, between the pistons.
5. Rotate the pinion with a wrench to assure it and the pistons moves freely.
6. Install the position indicator and the snap ring.
7. Assemble the washer on the flange, install the 2 flange bolts, do not over tighten.
8. Insert the end cap O-rings into their grooves by following the shape of the grooves with a finger. Ensure that the O-rings are properly seated.
9. If this is a spring return unit install the spring cartridges into the holes in the pistons.
10. Install the end caps and end cap screws. Tighten the screws in an alternating order. Do NOT OVER TIGHTEN.

HAYWARD INDUSTRIAL PRODUCTS INC.

One Hayward Industrial Drive
Clemmons, NC 27012
Phone: 336-712-9900 Fax: 336-712-9518
www.haywardflowcontrol.com

PMSIOM

Rev. B
Aug 10, 2004
ECR 681T