



## NPD Series Solenoid Valves

### True Union



#### Overview

Heavy-duty solenoid valves feature true union end connections and are designed so No Pressure Differential is required for reliable operation. Problems such as sticking and “chattering” are eliminated and downstream restrictions caused by nozzles, flowmeters, and other equipment will not affect performance. The valve’s unique coil design results in lower coil operating temperatures and a 100% continuous duty rating. A molded polyester housing protects the coil assembly and electronics from harsh corrosive environments, and an easy to replace one-piece seal cartridge and plunger assembly allow the valve to quickly be put back in service.

#### Features

- Continuous 100% Duty Cycle
- Multi-Position Electric Connections
- Polyester Coil Housing
- 115 VAC Standard
- Corrosion Resistant
- Built-In 1/2” Conduit or S-J Type Cord Electric Connections
- FPM or EPDM Seals
- NPD Design
- 1/4 - 1” PVC, Corzan® CPVC

#### Options

- Voltage Options:  
12 VAC/VDC, 24 VAC/VDC, 220 VAC

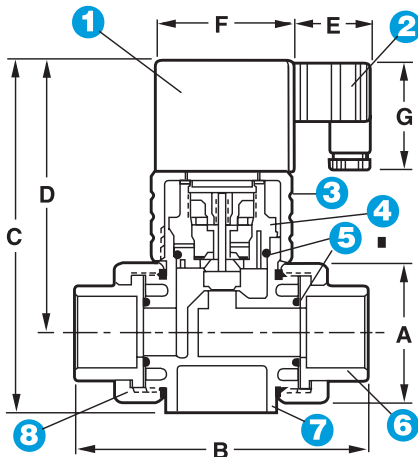

#### Parts List

##### True Union Solenoid Valves

- 1 Solenoid Coil
- 2 Electrical Connector
- 3 Bonnet Nut – CPVC
- 4 Seal Cartridge – CPVC, PVC
- 5 O-Rings
- 6 End Connector – PVC/CPVC
- 7 Body – PVC/CPVC
- 8 Union Nut – PVC/CPVC

#### Operating Parameters

For optimum valve performance, inlet pressure must not exceed 120 PSI. Flow rate should not exceed 5 feet per second.

#### Pressure Loss Calculation Formula

$$\Delta P = \left[ \frac{Q}{C_v} \right]^2$$

$\Delta P$  = Pressure Drop  
 $Q$  = Flow in GPM  
 $C_v$  = Flow Coefficient

#### Cv Factors

Size	Factor	Size	Factor
1/4"	1.3	3/4"	3.2
1/2"	2.3	1"	3.8

#### Dimensions–Inches

Size	A	B	C	D	E	F	G	Weight (lb/kg)
1/4"	2.25	5.30	6.30	4.60	1.60	2.60	2.00	2.79/1.3
1/2" /20*	2.25	5.30	6.30	4.60	1.60	2.60	2.00	2.81/1.3
3/4" /25*	2.63	5.50	6.60	5.10	1.60	2.60	2.00	3.01/1.4
1" /32*	2.63	5.50	6.60	5.10	1.60	2.60	2.00	3.03/1.4

\* Metric End Connections Available in: BSP – Straight Thread, BSP TR – Tapered Thread and Metric Socket

Corzan® is a registered trademark of Noveon, Inc.



## Technical Information

### Part Numbers

PVC/FPM Seals			CPVC/FPM Seals		
Size	End Conn.	Part Number	Size	End Conn.	Part Number
1/2"	Socket/Threaded	SV10050STV	1/4"	Socket/Threaded	SV20025STV
3/4"	Socket/Threaded	SV10075STV	1/2"	Socket/Threaded	SV20050STV
1"	Socket/Threaded	SV10100STV	3/4"	Socket/Threaded	SV20075STV
			1"	Socket/Threaded	SV20100STV

PVC/EPDM Seals			CPVC/EPDM Seals		
Size	End Conn.	Part Number	Size	End Conn.	Part Number
1/2"	Socket/Threaded	SV10050STE	1/4"	Socket/Threaded	SV20025STE
3/4"	Socket/Threaded	SV10075STE	1/2"	Socket/Threaded	SV20050STE
1"	Socket/Threaded	SV10100STE	3/4"	Socket/Threaded	SV20075STE
			1"	Socket/Threaded	SV20100STE

### Solenoid Valve Selection Chart

Size	Material	End Conn.	Liner & Seals	Pressure Rating	Coil Rating
1/4", 1/2" 3/4", 1"	PVC*, CPVC	Socket, Threaded, or Flanged	FPM, EPDM	150 PSI @ 70°F Non-Shock 120 PSI Max Inlet Pressure	1.6 Amp @ 120 VAC

\*1/4" not available in PVC

### Operating Temperatures/Pressure

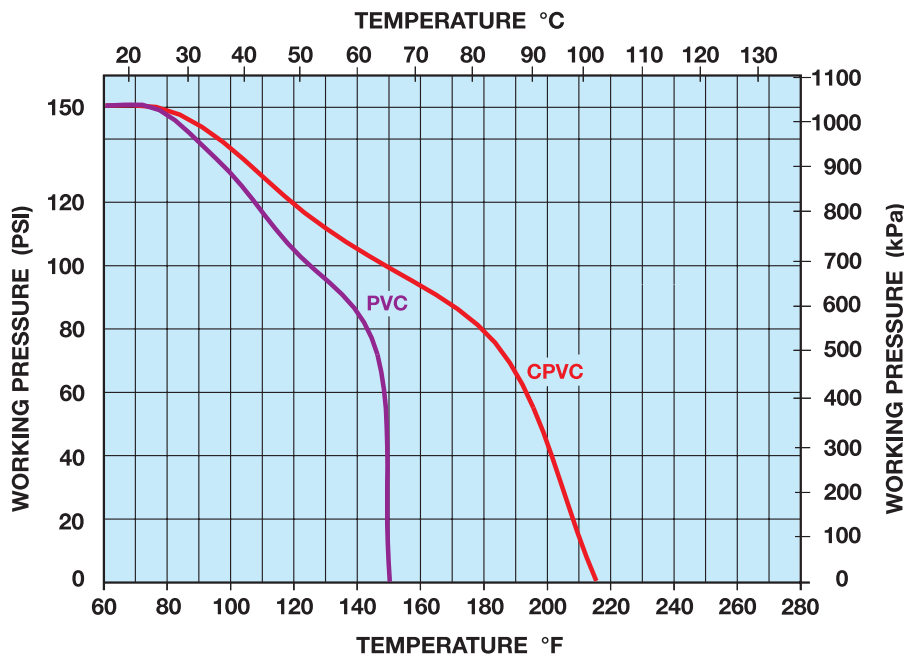

ELECTRIC ACTUATION